

# THE DALEK

**BUILD  
THE ICONIC  
BBC**



**MONSTER**



**DALEK TERROR  
IN 1866!**



**STEP-BY-STEP  
INSTRUCTIONS**

Published  
weekly • £11.99  
AUS • \$23.99



# DALEK

## ISSUE 79



### ADVENTURES IN TIME AND SPACE: THE EVIL OF THE DALEKS - PART 4

3

The Doctor observes as Jamie fights to rescue Victoria from the Daleks.



### THE TIME VORTEX: DAVROS - PART 8

6

Davros is put on trial by his own Dalek creations.

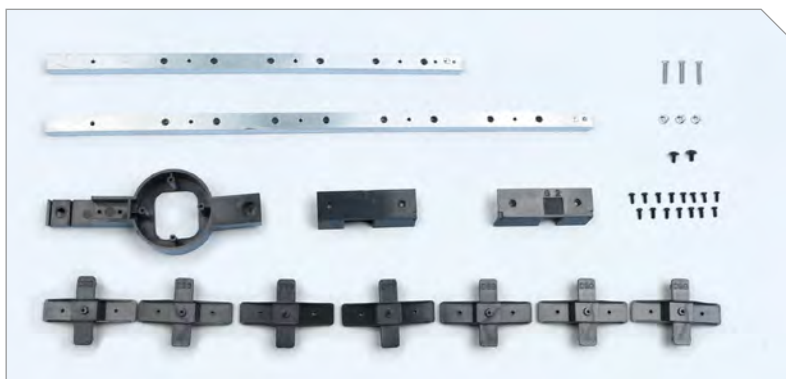

### STEP-BY-STEP BUILD: PART 79

8

Side supports, joints, skirt fixings and a circuit board switch holder.

## Reader Services

CUSTOMER SERVICE IN THE UK  
AND REPUBLIC OF IRELAND

### How to continue your collection:

Subscribe online at [hachettepartworks.com/Dalek](http://hachettepartworks.com/Dalek) or contact the Customer Service team via [hachettepartworks.com/contact](http://hachettepartworks.com/contact)

### Customer service & back orders:

Please visit [hachettepartworks.com/contact](http://hachettepartworks.com/contact) to get in touch.

UK call 0345 155 9277

ROI call (01) 9079762

(Calls are charged at your local rate from a landline)

Published by Hachette Partworks Ltd  
4th Floor, Jordan House, 47 Brunswick Place, London N1 6EB

General Manager – Isabelle Couderc  
Editorial Director – Helen Nally  
Marketing Director – Elise Windmill  
Production Director – Sema Sant Anna  
Managing Editor – Sarah Gale  
Distribution Manager – Paul Smith  
Product Manager – Rhys Myner

Packaged by Panini Publishing, a division of Panini UK Limited.

Publishing Director Europe – Marco M. Lupoi  
Managing Director – Chris Clover  
Managing Editor – Alan O'Keefe  
Senior Editor – Karen O'Brien  
Editor – John Ainsworth  
Designer – Barry Spiers  
Features Writer – Stuart Ashley

Distributed in the UK and Republic of Ireland by Marketforce.

© 2026 Hachette Partworks Ltd

Printed in the UK.

ISSN 2977-5574

ALL RIGHTS RESERVED

The editor's policy is to use papers that are natural, renewable and recyclable products and made from wood grown in sustainable forests. The logging and manufacturing processes are expected to conform to the environmental regulations of the country of origin.

In the event of a significant increase in production and transport costs, the publisher reserves the right to modify its selling prices.

BBC, DOCTOR WHO, TARDIS and DALEK (word marks and devices) are trade marks of the British Broadcasting Corporation and are used under licence. BBC logo © BBC 1996. DOCTOR WHO logo © BBC 1973. Dalek image © BBC/Terry Nation 1963. Licensed by BBC Studios.

The device complies with Part 15 of the FCC Rules. Operation is subject to the following two conditions: (1) this device may not cause harmful interference, and (2) this device must accept any interference received, including interference that may cause undesired operation.

All parts belong to a kit. NOT SUITABLE FOR CHILDREN UNDER THE AGE OF 14. This product is not a toy and is not intended for use in play. Follow the instructions in the enclosed magazines carefully and keep the appropriate information in a safe place. The installation of the electrical and electronic parts must always be carried out by an adult. Requires batteries.

BBC



For our environmental policy in full please scan the QR code here.

hachette  
PARTWORKS LTD



# THE EVIL OF THE DALEKS

## PART 4

**Jamie finds an ally in Kemel, and together they search for Victoria Waterfield.**

**Season 4 Episode 40  
First Broadcast: 10 June 1967**

Jamie walks down a corridor and finds Kemel waiting for him at the top of a flight of stairs. Jamie cautiously climbs the stairs to him. "Hello. Who are you?" he asks. Kemel raises his massive arms and advances on Jamie, grabbing him by the throat. Jamie tries to punch him, but the giant Turk simply catches Jamie's fist in his hand. Kemel

shoves Jamie down the stairs, but Jamie grabs the banister and manages to keep his footing. Kemel races down the stairs as Jamie snatches up a large porcelain vase from a wooden plinth. He whirls around and sends it crashing down on Kemel's head. Kemel falls back, stunned.

Jamie runs, but Kemel soon catches up with him. The pair grapple, but once again Jamie is outmatched by Kemel's strength. Jamie punches him, but the Turk shoves him against a wall. Jamie pushes back and manages to knock Kemel over a balustrade. He falls onto a table, breaking it. Kemel lies still, dazed. Jamie looks down at his opponent for a moment, then heads into a storeroom, closing the door behind him. Kemel rises up and pursues him. He charges

at the door, intending to smash it down, but Jamie is ready. He opens the door just before Kemel hits it. The Turk races across the storeroom and, unable to stop himself, goes tumbling out of an exterior exit.

Jamie looks outside and sees Kemel barely clinging to the roof guttering, a long drop below him. Jamie finds some rope and throws it to Kemel. His muscles straining, Jamie provides an anchor so that Kemel can climb back onto the roof. Kemel makes it safely back inside. He faces Jamie, surprised by the compassion his enemy has shown him. He is uncertain what to do. Jamie walks out of the storeroom. Nearby, a Dalek drops a white handkerchief on the floor of Victoria's



former cell. It has the initials "VW" embroidered on it. The Dalek quickly retreats into the shadows.

Jamie enters the cell and sees the handkerchief, but before he can pick it up, Kemel shoves him forward. An axe swings down, missing Jamie by inches. Jamie realises that Kemel has now saved his life in return.

In a small room nearby, the Doctor examines the readings from the Dalek machines. He is monitoring Jamie's



emotions and thought patterns. A Dalek observes him. "It took courage to fight Maxtible's Turkish wrestler," the Doctor comments. The Dalek replies that its race fears nothing. "But Jamie saved the Turk's life," the Doctor adds. The Dalek dismisses this as human weakness. "If he hadn't, he would have died in that room of yours," the Doctor points out. "If you want the Human Factor, a part of it must include mercy."

Maxtible and Waterfield find Toby's body in the laboratory. Waterfield is horrified at the sight of another dead man. A Dalek emerges from the time cabinet. "You will hide the remains of the dead human intruder," it commands. Maxtible finds a sheet and wraps Toby's body in it. A guilt-stricken Waterfield doesn't want to help. "We are not to blame for what has happened!" Maxtible tells him. "No English judge or jury would find it in their hearts to convict us of one solitary thing!" A solemn Waterfield tells Maxtible that once he has freed Victoria, he will confess everything to the authorities. Maxtible eyes Waterfield suspiciously. Secretly, he pulls a pistol from a desk drawer and hides it beneath his jacket.

Meanwhile, Kemel writes his name in some dust to introduce himself to Jamie. They agree to be friends and work together to rescue Victoria. "There's no one I'd rather have with me," Jamie says, smiling.

Maxtible and Waterfield carry Toby's body to the stables. Waterfield is becoming increasingly distressed by the part he has played in the deaths of Kennedy and Toby. "Waterfield, I am sick to death of



you!" Maxtible snaps. He points out that he has provided everything Waterfield has asked for. "I did not bring these terrible creatures here deliberately!" he says. "It's your daughter they have kidnapped! One moment you beg me to do everything I can to rescue her, next moment, you blame me!" Maxtible succeeds in increasing the man's sense of guilt. A chastened Waterfield leaves.

Arthur Terrall emerges from the shadows and orders Maxtible to go back to the house while he deals with the body. "You will obey!" Terrall says, his eyes cold.

Jamie steps on a hidden switch and quickly warns Kemel. A mace swings down from the ceiling but misses them. The Doctor programs more of Jamie's



## TAKE A BREAK



he monitors Jamie's adventures with Kemel and speaks to a Dalek about the different aspects of human nature. Troughton pre-filmed these at Ealing Studios and, as a result, was not required for rehearsals or the main studio recording that week.

Episode 4 of *The Evil of the Daleks* was scheduled to allow *Doctor Who*'s star, Patrick Troughton, his first break from recording the series. The only scenes involving the Doctor take place in a single setting, where

## STRONG AND SILENT



was supposed to crash underneath me and I'd fall on the ground. So, they sawed the legs of the table halfway through so when I fell on it, it would crumple. But when I went over the balustrade, the table was still standing! I went up again, and the same thing happened! They sawed it a little bit more, and I went over again, and the table collapsed! It was so funny!" After *The Evil of the Daleks*, Caldinez returned to *Doctor Who*, playing Ice Warriors in four stories: *The Ice Warriors*, *The Seeds of Death*, *The Curse of Peladon*, and *The Monster of Peladon*. He also appeared in numerous films including *Raiders of the Lost Ark*, *The Man with the Golden Gun*, and *The Fifth Element*.

Sonny Caldinez played Kemel. Born in Trinidad, he moved to England at the age of 20, where he worked first as a professional wrestler, then as a stunt man, and finally as an actor. His first film was a Bob Hope vehicle, *Call Me Bwana*. He recalled the famous fight scene in *The Evil of the Daleks*: "I was supposed to be hit by Jamie, fall over a balustrade onto a table, and the table



thought patterns into the machine. "We do not trust you," the Dalek tells him. "What thoughts are you using now?" The Doctor explains that human beings have instincts in addition to their five senses: "Jamie used instinct to avoid your trap."

A fearful Victoria walks out of her room and stands on a gallery above a hallway. A Dalek demands that she call out her own name. She does as she is instructed, and Jamie and Kemel hear her. She then returns to her room. Kemel prepares for battle, taking a mace from the wall, but Jamie thinks a frontal assault on the Daleks would be too dangerous.

The Dalek asks the Doctor about the significance of the thought patterns he is entering. "Suicidal attacks to gain an



objective are stupid," the Doctor replies. "Self-preservation is a strong human factor. Jamie and his new friend are determined to succeed. But finding the girl is only part of the objective. Getting her away is another."

Arthur Terrall becomes furious with Mollie when she says she heard Victoria's voice. She runs off crying. Ruth is very concerned for her fiancé, and wonders if her father has somehow influenced him. She urges him to leave the house with her.

Meanwhile, Maxtible and a Dalek talk in the laboratory. Maxtible attempts to reassert his position, claiming that he and the Dalek are partners. "It is not beyond me to ruin the entire enterprise," he says. The Dalek knocks him to the floor. "Do not threaten! Obey!" it shouts. The Dalek glides back toward the time cabinet, but Maxtible begs it to wait. "The secret! You promised to give it to me!" he cries. "The Daleks know many secrets," it replies. "You will learn the most important." The Dalek departs.

Ruth enters the laboratory. She wants to know why Terrall has changed and to find out where Victoria is. Maxtible avoids his daughter's questions but reveals that he is searching for the solution to one of the great mysteries of history: "The transmutation of metal into gold!" He declares that nothing will stop him from discovering the secret.

Once again, Victoria is made to call out her name from the gallery before returning to her room. Jamie and Kemel each take the end of a rope and use it



to force a Dalek back into a fireplace, destroying it. Jamie uses the rope to climb up onto the gallery. When Kemel follows, his greater weight puts a strain on the banister, which begins to crack. Jamie helps him reach the gallery safely and then he tries the door to Victoria's room. "Miss Waterfield!" he calls. "Can you open the door? We've come to get you!" Another Dalek appears on the floor below them, drawing Jamie and Kemel's attention. They do not notice a second Dalek coming out of the shadows behind them...



## FIGHT ARRANGER



Stunt expert Peter Diamond arranged the fight between Jamie and Kemel: "I fenced in the British Army, then gained an actor's scholarship at the Royal Academy of Dramatic Art." Diamond also worked as theatre fight director at the British National Theatre. In the 1960s, he found plenty of work on TV series like *Doctor Who*, *The Saint*, and *Ivanhoe*, as well as Hammer Studios' horror films, both as a stunt arranger and as an actor: "I understand actors through my background and can consequently discuss a dramatic sequence with them when coordinating a fight sequence." Diamond went on to arrange fight scenes for many films, including *The Princess Bride*, *Raiders of the Lost Ark*, and the original *Star Wars* trilogy.

# DAVROS

## PART 8

**D**avros was being held in a security base on Skaro, hidden high in the Scalohin Mountains. When he had been taken from Necros, he assumed that he would be brought to the main Dalek city, but apparently it had been destroyed during the war with the Movellans. The Daleks were in an even weaker position than he had realised. "Good," he thought.

Davros was escorted into a large, darkened chamber and placed in the centre of a floating platform. A spotlight fell on him. His optic scanner pierced the darkness – he could just make out the looming forms of a thousand Daleks, all watching silently.

Another trial, he thought bitterly. The fact that his own creations were daring to judge him made him seethe with rage, but he knew better than to display any emotion. That would only be seen as a sign of weakness.

The new Supreme Dalek glided onto the platform. It was black, with silver hemispheres, much like its predecessor. That one had died when Davros' prison ship had exploded, taking the Supreme Dalek's battlecruiser with it in the blast.

The Supreme Dalek addressed the Daleks. "Davros has betrayed the Daleks!" it said. "He altered the minds of Daleks to make them obey him! He intended to conquer and eradicate us!"



Davros refuses to accept defeat.

There was a low rumbling in the Dalek audience as they processed this information. The Supreme Dalek continued: "His greatest crime was perverting the purity of the Dalek race. He transformed humans into a mockery of the Dalek form. He planned to destroy us with his army of false Daleks!"

The Supreme Dalek allowed the Daleks a moment to fully grasp the enormity of what it had said and then added, "Davros is a traitor to the Dalek cause. He must be exterminated!"

The entire audience seemed to shift like a violent wave: "Exterminate! Exterminate! EXTERMINATE!" Their voices echoed across the vast chamber, growing louder and louder.

Davros glided forward and stared at the mass of Daleks observing him. He had always been a powerful orator. He had enjoyed giving speeches to his fellow Kaled scientists, raising their morale when progress had been slow and uncertain. He had also spoken many times to the Kaled political and industrial elite, stirring their patriotic pride as he urged them to fund his research. He could sway the hardest of hearts. But could he change the mind of a Dalek?

"Look at yourselves, my Daleks!" he said, his voice rising with conviction. "You were once the mightiest race in the cosmos, thanks to my design! Now you have been reduced to a mere handful, hiding from humanity, a faint, pitiful echo of what you once were! Ask yourselves this: why?"

No reaction. Davros continued. "You could not defeat the Movellans because you had no imagination! No instinct! But I can share these gifts with you!"

There were now signs of life in the audience. Some dome lights were visible. Davros carried on. "I am the fire from which you were first forged! I am your only hope to regain your greatness! Only I can make the universe tremble again at the sound of your name! With me to command you, the Daleks will be triumphant!"

The Daleks were stirring now, moving their domes, making excited noises.

It was working, Davros thought. If he could just keep the momentum –

"SILENCE!"

The air was suddenly still. The Supreme Dalek glided towards Davros. He could sense its fury. "Your desire to lead the Daleks is futile! You are not a Dalek! All non-Daleks are inferior lifeforms! Daleks can never follow an inferior!"

Davros almost smiled. He had been expecting this. He turned to the Dalek audience again. "So be it!" he cried. "I shall become a Dalek! I shall integrate my body within a Dalek shell, and my organs shall be entwined with Dalek technology! I shall become the ultimate Dalek! I SHALL BE YOUR EMPEROR!"

For a moment there was only silence. Then, hesitantly, a single Dalek in the audience spoke his name: "Dav-ros..." Another followed it, slightly louder: "Davros." Then another: "Davros!" And another. And another: "Davros! Davros!"

And then it was being shouted: "DAVROS! DAVROS! DAVROS! DAVROS!" The chamber began to shake as the sound of the name reverberated through its walls. The room blazed with a thousand flashing dome lights as the Daleks chanted in unified rhythm.

The Supreme Dalek turned like lightning towards Davros, its gunstick aimed at his head. "No!" it screeched. "You are not fit to rule the Daleks! You will die!"

A gunstick fired a beam of energy, but it was not the Supreme Dalek's. It came from one of the Dalek wardens on the side of the platform. It struck the Supreme Dalek. A small explosion erupted from its upper casing. "You will not harm Davros!" the warden shouted. But the Supreme's superior armour had saved it from destruction. It whirled around and returned fire on the warden, obliterating it.

Other Daleks were now swarming onto the platform. Energy beams crisscrossed the air. Daleks were exploding. Some were defending the Supreme Dalek, but most were protecting Davros.

"Emergency transmat!" the Supreme Dalek commanded. A halo of white energy surrounded it and a handful of its nearest followers. In an instant, they were gone.

In less than an hour, the remaining Daleks on the base still loyal to the Supreme Dalek had been destroyed. However, there was no trace of Davros' adversary. He knew his enemy was cunning and resourceful. It would have to be found and eliminated as soon as possible.

But for the moment, Davros allowed himself a moment of quiet. He leaned back and stared up at the stars.

They would all be his soon enough.

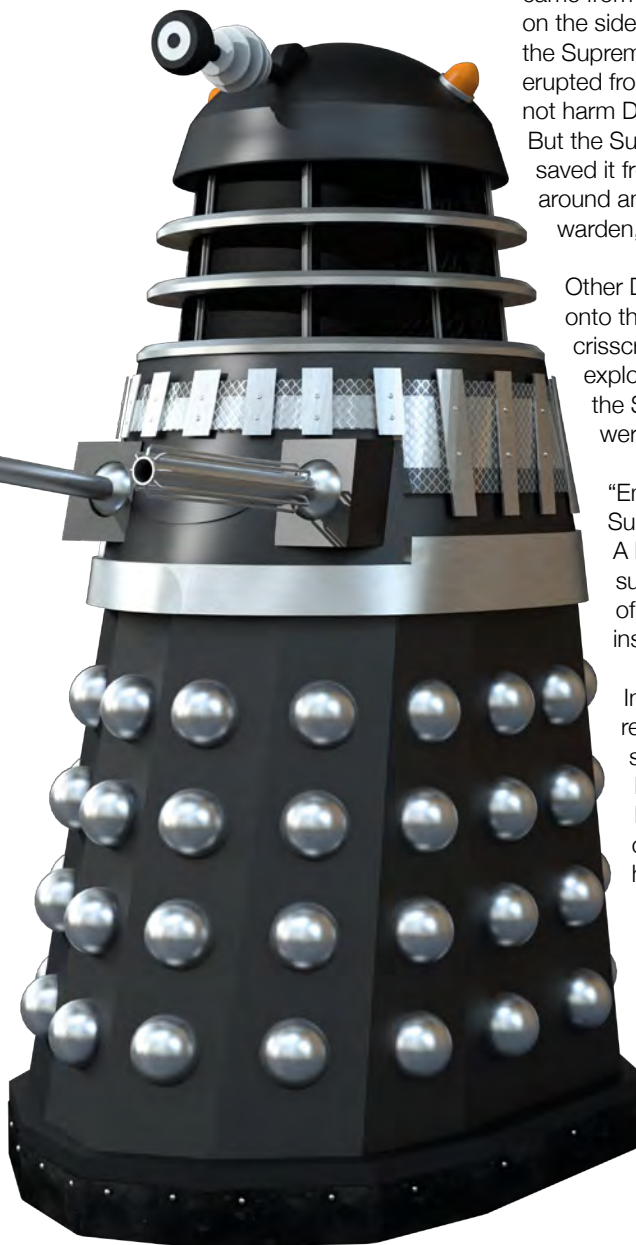

# BASE SECTION

## INTERNAL SUPPORT STRUCTURE

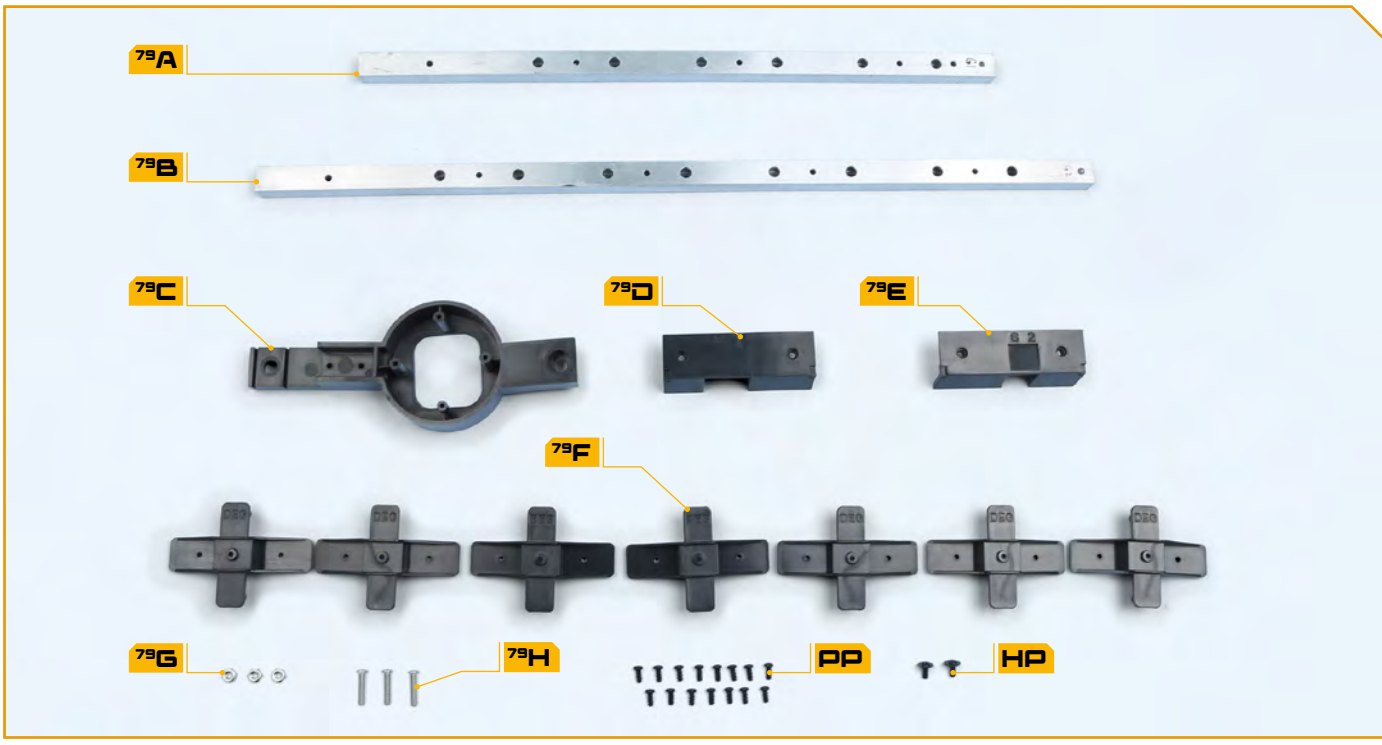

### COMPONENTS OF ISSUE 79

- 79A** SIDE SUPPORT (labelled G1)
- 79B** SIDE SUPPORT (labelled G2)
- 79C** CIRCUIT BOARD SWITCH HOLDER
- 79D** SIDE SUPPORT TOP JOINT (labelled G1)
- 79E** SIDE SUPPORT TOP JOINT (labelled G2)
- 79F** SKIRT FIXING PART (x 7, labelled DEG)
- 79G** NUTS (x 3, 1 spare)
- 79H** BOLTS (x 3, 1 spare)
- PP** FIFTEEN 2.6 X 6MM PB SCREWS (1 spare)
- HP** TWO 2.6 X 6MM PWB SCREWS (1 spare)
- 
- 
- 
- 
- 

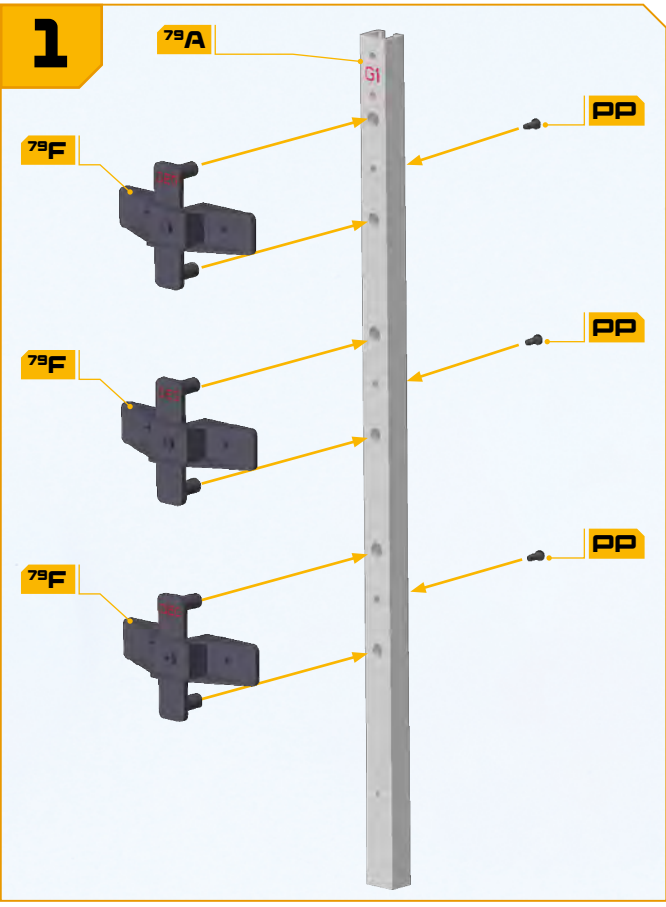

**#79-01**  
 Take the side support **79A** (marked G1) and three skirt fixing parts **79F**, marked DEG. Position them as shown, so that the raised screw holes on the skirt fixing parts fit into the large holes in part **79A**. Note that the label G1 on part **79A** is at the top, between two small screw holes. Fix each fixing part in place from the back of the side support **79A** with a **PP** screw.

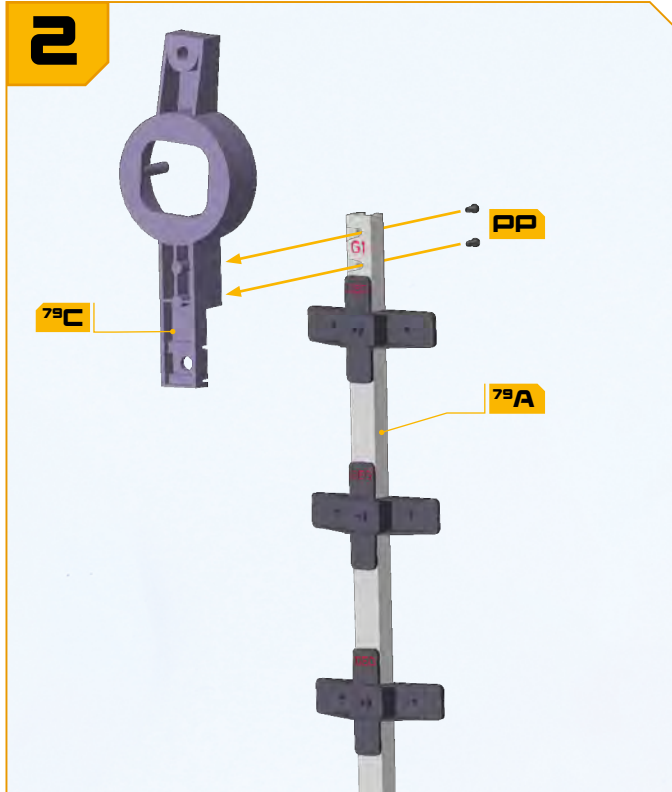

#### #79-02

Take the circuit board switch holder **79C** and check how it fits at the top of part **79A**. Screw sockets on the lower end of part **79C** align with screw holes in part **79A**. Fix in place with two **PP** screws.



#### #79-03

Take the side support top joint (labelled G1) **79D** and fit the top of the circuit board switch holder **79C** into the recess so that screw holes are aligned. Note the orientation of the parts with the channel in part **79A** and the raised screw sockets in parts **79C**, facing forwards in this illustration. Fix in place with an **HP** flange head screw.

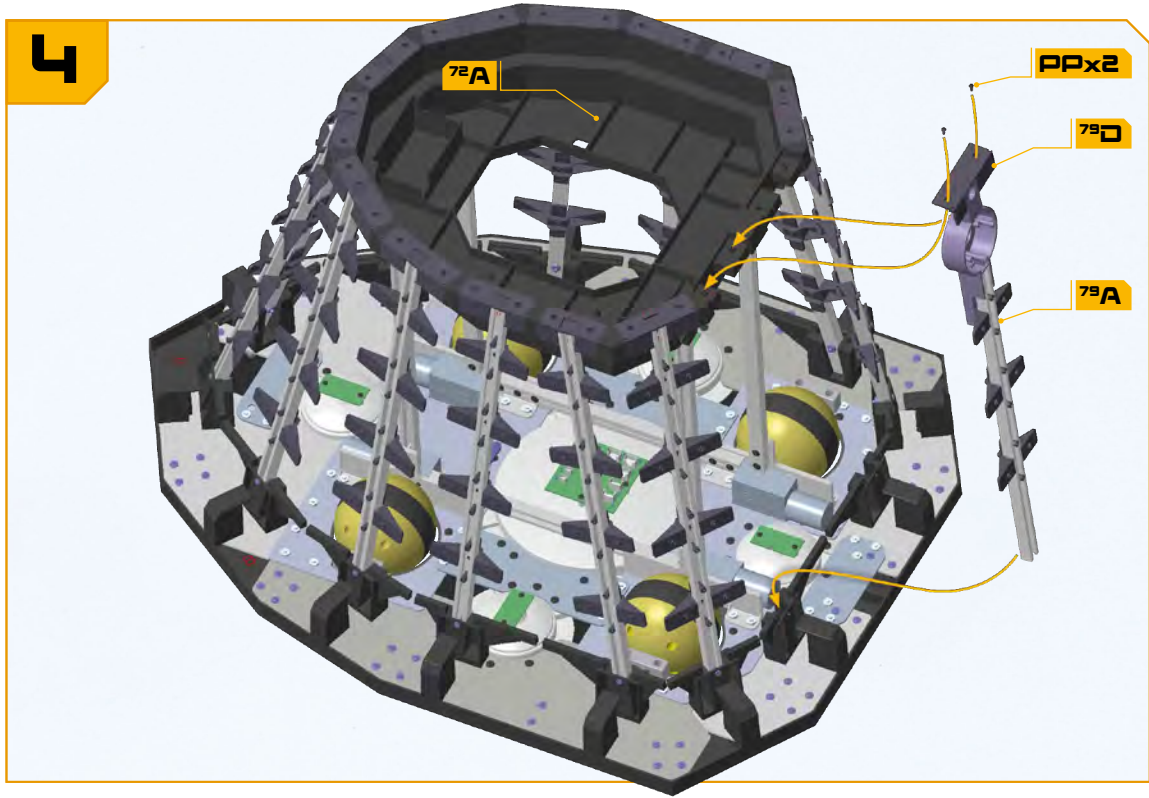

#### #79-04

Fit the base of the side support **79A** into the channel in the skirt support at the rear left-hand side of the model. Fit the top joint **79D** into the corresponding shape marked G1 in the back of the chest support **72A**. Fix in place with two **PP** screws.

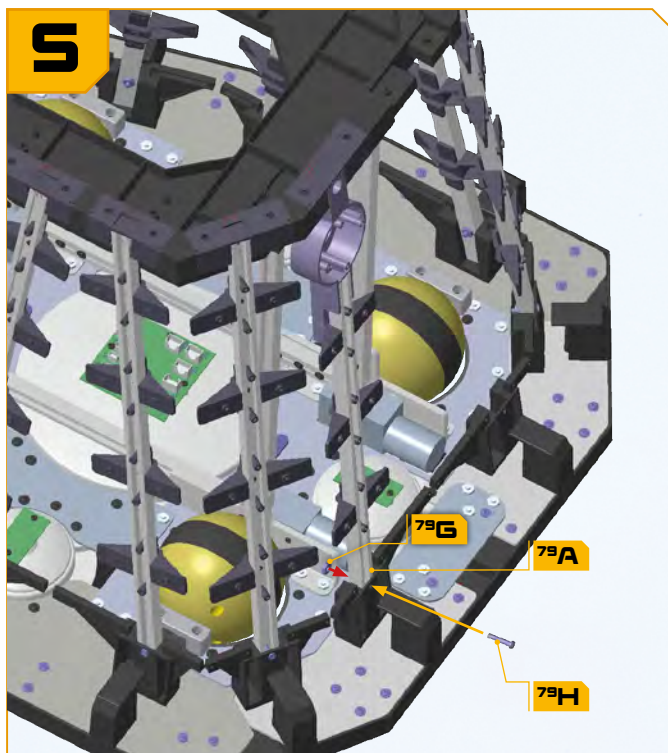

**#79-05**

Fit a bolt **79H** through the screw holes in the skirt holder and part **79A** (yellow arrow). Fit a nut **79G** on the end of the bolt to hold it in place (red arrow). Use the spanner **38F** to help tighten the nut if necessary.

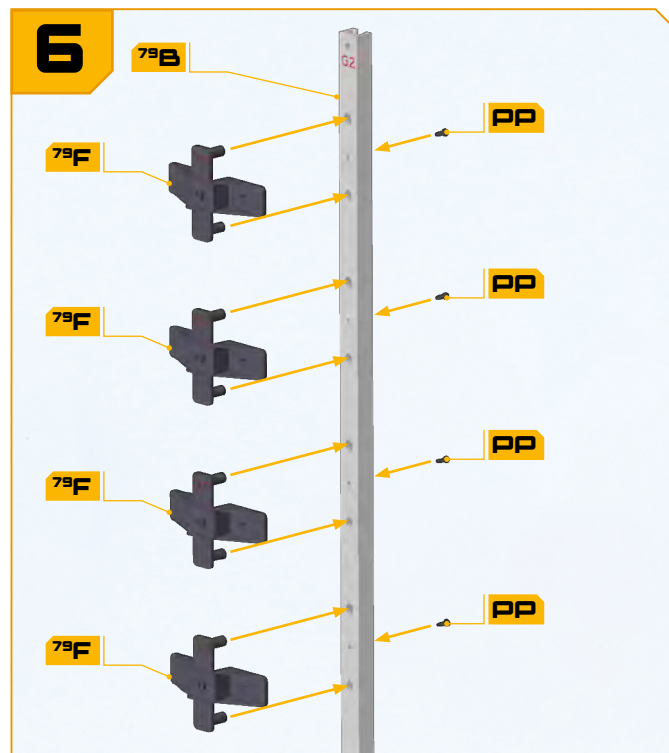

**#79-06**

Take the side support **79B** (marked G2) and four skirt fixing parts **79F** (marked DEG). Position them as shown, so that the raised screw holes on the skirt fixing parts fit into the large holes in part **79B**. Fix each fixing part in place from the back of the side support **79B** with a **PP** screw.

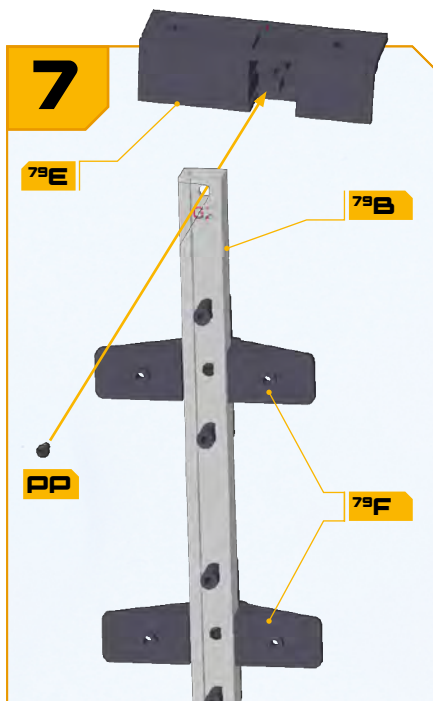

**#79-07**

Take the side support top joint (labelled G2) **79E** and fit the top of part **79B** into the recess so that screw holes are aligned. Note the orientation of the parts with the channel in part **79B** and the raised screw sockets in parts **79F**, facing forwards in this illustration. Fix in place with a **PP** screw.

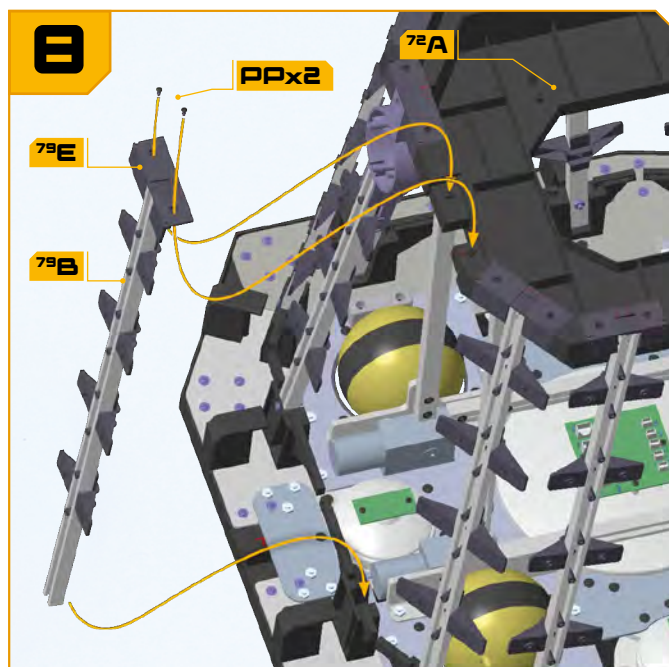

**#79-08**

Fit the base of the side support **79B** into the channel on the inner side of the skirt support at the rear right-hand side of the assembly. Fit the top joint **79E** into the corresponding shape in the side of the chest support **72A**, which is marked **G2**. Fix in place with two **PP** screws.

### #79-09

Fit a bolt **79H** through the screw holes in the skirt support and part **79B** (yellow arrow).

Fit a nut **79G** on the end of the bolt to hold it in place (red arrow). Use the spanner **38F** to help tighten the nut if necessary.

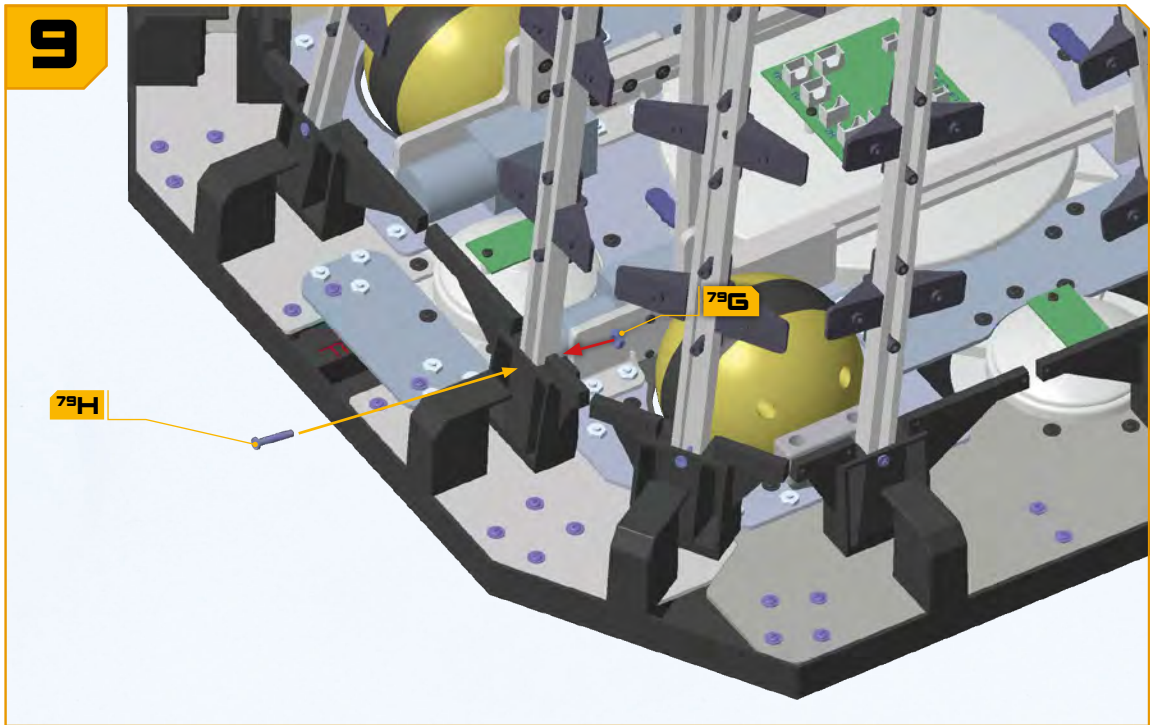

### COMPLETED WORK

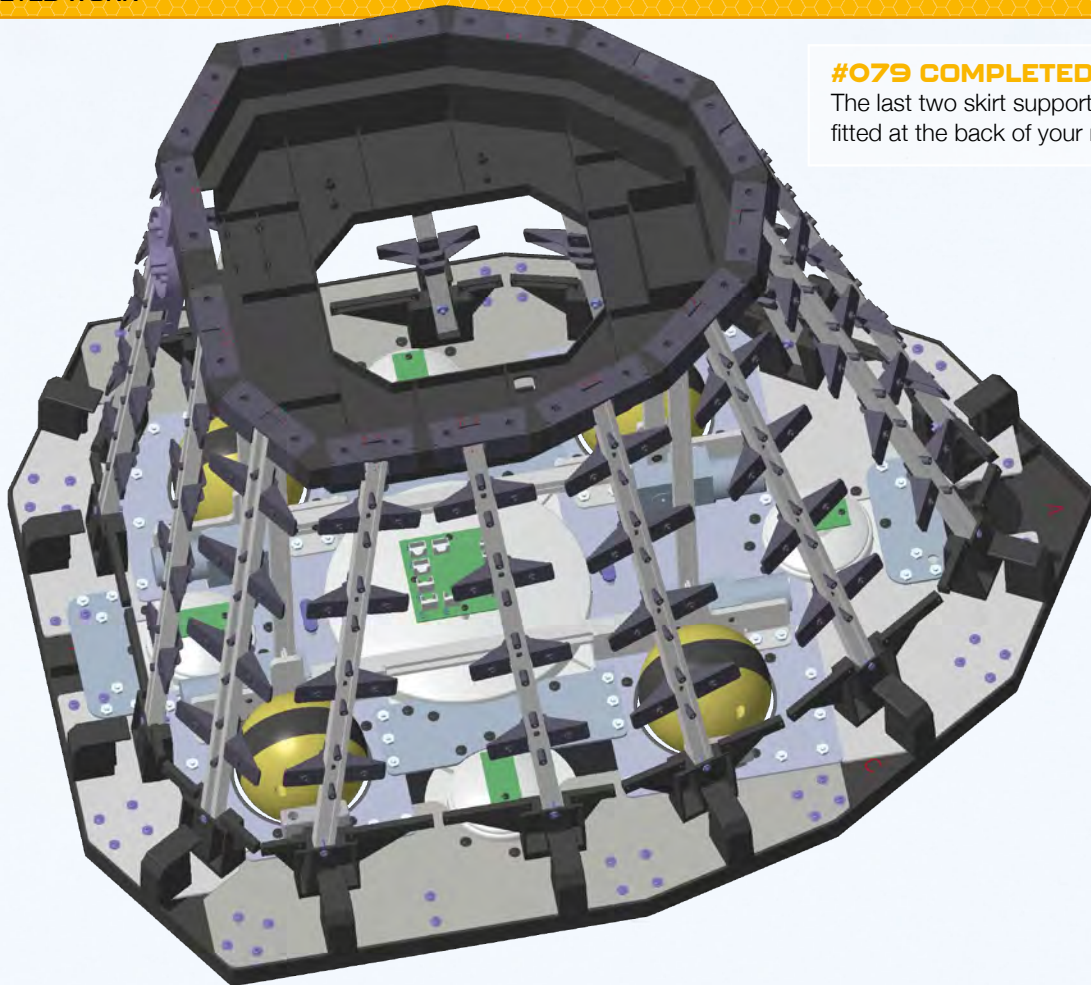

### #079 COMPLETED WORK

The last two skirt supports have been fitted at the back of your model.

# THE DALEK



COMING IN  
ISSUE 80

## BUILD PART 80

Issue 80 begins the installation of the internal wiring with cables for the base motor and base lights, two cable ties, nine packets of screws, and a cotton glove to handle any thin metal parts.

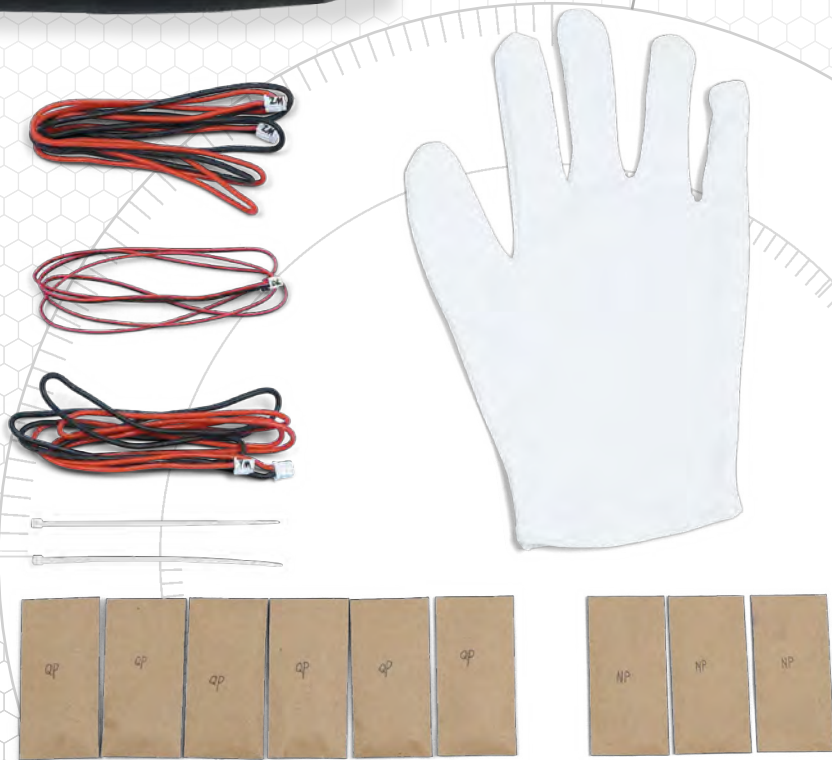

### ANATOMY OF A DALEK



The Dalek Drones are the footsoldiers of the Dalek empire – fearless, ruthless and loyal to the Dalek cause.

### ADVENTURES IN TIME AND SPACE



The Doctor and his companions discover that escaping London is fraught with danger in *The End of Tomorrow*.

Every week at your newsagent! Visit [hachettepartworks.com/Dalek](http://hachettepartworks.com/Dalek)